

PRESS ON ACCESS DOORS (HINGE & CAM) (H)

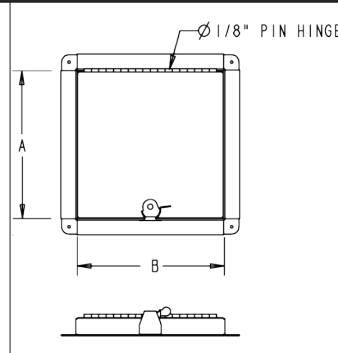

Product Data Sheet



Description

AirZoe's Press On Hinge & Cam (H) is used to provide easy access into rectangular ductwork. Double paneled with front and back metal plates, and 1" insulation

Standard Construction

Door Panel:

Consists of 24GA GA, manufactured from ASTM A-653 G60, panels mechanically locked together.

Insulation:

1" high-density fiberglass insulation Classifications; FHC25/50, ASTM C 1071; Type 1, ASTM G 21, Greenguard Indoor Air Quality Certified*, Greenguard Children and Schools, NFPA 90A and 90B.

Gasket:

Closed-cell neoprene gasket is UL94HF1 listed with service temperature range of 20° F to 200° F The gasket is bonded to the inside of the frame.

Press-on Frame:

Measuring 6" x 6" to 12" x 12" are manufactured from 24 gauge galvanized steel. Frames measuring 14" x 14" to 24" x 24" are manufactured from 22 gauge galvanized steel.

Cams & Strikes:

The cam is stamped using 16 Ga galvanized steel. The latch is stamped from 20 Ga galvanized steel. Each cam is secured to the door with a rivet. The latch is secured to the frame in two locations for added rigidity.

Features

- Meets 2005 SMACNA Standards for pressure class & gauges(Refer tp page 7-2, figure 7-2)
- Union Made
- Regular doors can be used up to 4"wg
- High Pressure doors can be used up to 10"wg

Optional Construction

- Closed cell foam insulation(in place of fiberglass)
- Additional Cams
- 1.5" thick and 2" thick
- Neoprene gasket bonded outside of the frame
- Stainless Steel 304
- Stainless Steel 316
- Aluminum
- PCD
- Galvanneal (Paint Grip)

Hi-Pressure (Up to 10" W.G. +/-):

- 20GA and Fully Welded
- 1/16" Diameter Galvanized Cable-wire
- Locking Haps for Padlocks

Packaging

Size A x B	Flange Size	# of Cams	Box Qty	Weight (lbs)
6 x 6	1	1	48	1.3
8 x 8	1	1	20	1.9
10 x 10	1	1	20	2.7
12 x 12	1	1	16	3.6
14 x 14	1	1	5	5.5
16 x 16	1	2	5	7.2
16 x 12	1	2	5	5.8
18 x 18	1	2	4	8.8
18 x 12	1	2	4	6.4
20 x 20	1	2	4	10.5
24 x 24	1	2	4	14.5
24 x 12	1	2	4	8.2

Guarantee

D-VAC Sales Inc.
200B Verdi Street, Farmingdale NY 11735
Tel: 516-256-3131 sales@dvachvac.com
www.dvachvac.com

D-VAC
Commercial Corp